



21st Century Dam Design — Advances and Adaptations

31st Annual USSD Conference
San Diego, California, April 11-15, 2011

Hosted by
Black & Veatch Corporation
GEI Consultants, Inc.
Kleinfelder, Inc.
MWH Americas, Inc.
Parsons Water and Infrastructure Inc.
URS Corporation

On the Cover

Artist's rendition of San Vicente Dam after completion of the dam raise project to increase local storage and provide a more flexible conveyance system for use during emergencies such as earthquakes that could curtail the region's imported water supplies. The existing 220-foot-high dam, owned by the City of San Diego, will be raised by 117 feet to increase reservoir storage capacity by 152,000 acre-feet. The project will be the tallest dam raise in the United States and tallest roller compacted concrete dam raise in the world.

U.S. Society on Dams

Vision

To be the nation's leading organization of professionals dedicated to advancing the role of dams for the benefit of society.

Mission — USSD is dedicated to:

- Advancing the knowledge of dam engineering, construction, planning, operation, performance, rehabilitation, decommissioning, maintenance, security and safety;
- Fostering dam technology for socially, environmentally and financially sustainable water resources systems;
- Providing public awareness of the role of dams in the management of the nation's water resources;
- Enhancing practices to meet current and future challenges on dams; and
- Representing the United States as an active member of the International Commission on Large Dams (ICOLD).

The information contained in this publication regarding commercial projects or firms may not be used for advertising or promotional purposes and may not be construed as an endorsement of any product or from by the United States Society on Dams. USSD accepts no responsibility for the statements made or the opinions expressed in this publication.

Copyright © 2011 U.S. Society on Dams
Printed in the United States of America
Library of Congress Control Number: 2011924673
ISBN 978-1-884575-52-5

U.S. Society on Dams
1616 Seventeenth Street, #483
Denver, CO 80202
Telephone: 303-628-5430
Fax: 303-628-5431
E-mail: stephens@ussdams.org
Internet: www.ussdams.org

WEB-BASED REAL-TIME MONITORING AT PERRIS DAM USING IN-PLACE INCLINOMETERS AND PIEZOMETERS WITH AN AUTOMATIC NOTIFICATION SYSTEM

John Lemke, PE, GE¹
Mike Driller, PE, GE²
Dan Wilson, PhD³

ABSTRACT

A real-time monitoring system was used to monitor subsurface movements and groundwater levels at Perris Dam during the construction of a liquefaction remediation test section. The test section considered herein included dewatering, driving sheet piles, excavation and replacement of soil, and deep soil cement mixing. The California Department of Water Resources (DWR) implemented a geotechnical instrumentation program to automatically and continuously monitor changes in subsurface movements and groundwater levels using in-place inclinometers and electronic piezometers, respectively. Each remote station at the project site automatically transmitted readings to a server at selected time intervals using wireless Internet modems. Plots of in-place inclinometer displacement profiles and water elevation were monitored by DWR project team members via a secure web page during and after construction. Water levels and displacement profiles were calculated and compared automatically, in real-time, to pre-established threshold levels. The server computer was programmed to initiate phone calls to a list of designated project members whenever threshold levels were exceeded. Each automated message included the project name, remote station number, and relevant reading from the in-place inclinometer or piezometer instrumentation. The real-time monitoring system used at Perris Dam provided continuous feedback during remediation construction work and provided a cost effective way to achieve continuous field observation with an automatic notification system. This paper will discuss the specification, set up, and performance of the geotechnical monitoring system during the test section monitoring.

INTRODUCTION

Perris Dam, located in western Riverside County, California, is a 125-foot high earth dam extending 2.2 miles in length (Figure 1). A residential neighborhood is located immediately downstream of the dam. A 2005 California Department of Water Resources (DWR) study of the Perris Dam foundation indicated that thin sandy layers in the dam foundation are potentially susceptible to liquefaction and severe loss of strength during a large earthquake event. A test program was initiated to evaluate planned repair work scheduled for 2013. This paper describes a real-time monitoring system used to measure

¹ Geodaq, Inc., 3385 Lanatt Street, Suite A, Sacramento, CA 95819, (916) 930-9800, jlemke@geodaq.com

² Department of Water Resources, 1416 9th Street, Room 538, One Shields Ave., Sacramento, CA 95814, (916) 698-8724, driller@water.ca.gov

³ Center for Geotechnical Modeling, University of California at Davis, Davis, CA 95616, (530) 754-9761, dxwilson@ucdavis.edu

ground water levels and lateral subsurface displacements in an effort to ensure public safety during the test program construction.

BACKGROUND

While the foundation conditions at Perris Dam were considered adequate by the standards of practice during its design phase in the late 1960s and early 1970s, significant advances in soil liquefaction engineering, including soil sampling, testing, and computer modeling methods, have resulted in new interpretations of foundation conditions and predicted risk in performance. DWR performed a detailed study of the Perris Dam foundation in 2005 (DWR 2005). The 2005 study indicated that the presence of thin sandy layers in the dam foundation are potentially susceptible to liquefaction and severe loss of strength during a large earthquake event. Liquefaction of the foundation soils could potentially lead to slope failure of the dam and uncontrolled reservoir release from Perris Lake.

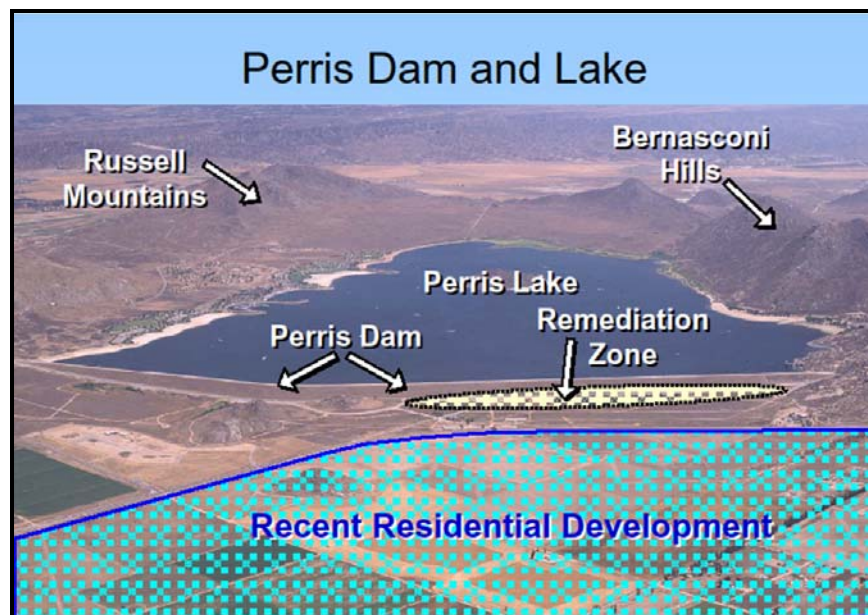

Figure 1. Perris Dam Project Location Image with Proposed Remediation Zone

In 2007, DWR and the Division of Safety of Dams (DSOD) jointly worked out a conceptual plan to remediate the liquefaction risk at Perris Dam. The plan included a combination of removal and replacement of the upper foundation soils, strengthening of deeper foundation soils using cement deep soil mixing (CDSM), and construction of a downstream berm. Prior to full construction of the planned remediation measures, it was decided to perform two types of test sections immediately downstream of the dam toe, as shown in Figure 2, to evaluate aspects of the design. The test section work included one dewatering test excavation to evaluate the dewatering of the foundation and one full-scale CDSM test section to verify that CDSM equipment, procedures, and mix design would produce the required soil improvement. Figure 3 shows the layout of the dewatering test excavation area. The vegetation visible immediately downstream of the dewatering test area is an indication of the seepage conditions at the site. In-place inclinometer and

piezometer instrumentation was installed at the dewatering test excavation area and formed an integral part of the real-time monitoring system operation prior, during, and after the construction of the dewatering test and excavation. The ground water table varies but on average is about 3.5 feet below ground surface in the area where the dewatering test excavation was performed.



Figure 2. Perris Dam Dewatering Test Excavation and CDSM Test Section

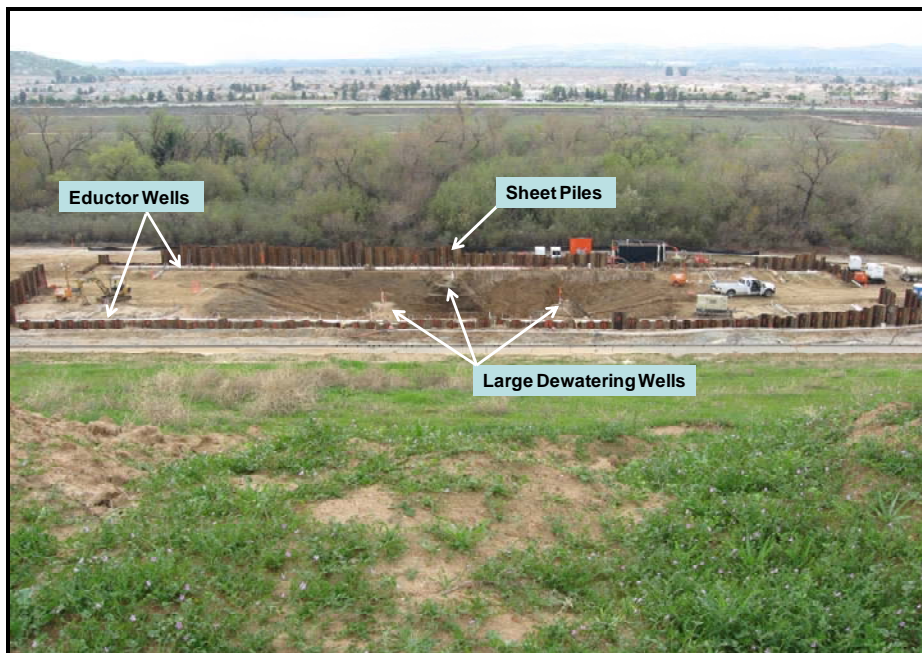

Figure 3. Perris Dam Dewatering Test Excavation, looking down from the crest.

INSTRUMENTATION AND MONITORING PROGRAM

The instrumentation and monitoring program for Perris Dam had three main goals: ensure safety during construction, evaluate performance during test section construction activities, and advance the state of practice for future DWR projects where monitoring is required. In order to meet these goals, the monitoring program would require instrumentation measurements at time intervals frequent enough to effectively evaluate the performance of the dam during dewatering and excavation construction activity. An automated monitoring system was selected for use on this project to meet the continuous sampling and reporting requirements and provide a means of real-time data evaluation and notification when reading levels exceeded established threshold values. Key components of the automated monitoring system included a relatively large number of sensors deployed at the site, frequent sampling of the sensors, wireless transmission of the sensor readings from the project site to a web server computer, real-time data evaluation of the sensor readings at the time of transmission to the server computer, computer evaluation of the reduced data and comparison to threshold criteria, automatic notification for any situation where the reduced data exceeded threshold levels, and delivery of meaningful reduced data plots to authorized users via an interactive software program at any time on any computer with Internet service and a common web browser.

Instrumentation

Ground water levels and slope stability performance of Perris Dam was monitored using piezometers and in-place inclinometer instrumentation. A total of 14 monitoring stations were installed at the project site. Ten model number PS9801 electronic piezometers manufactured by Instrumentation Northwest were placed at the bottom of open standpipe PVC piezometer casings to monitor changes in water level within the casing over the period of construction activity. The location and depth of each piezometer is shown in Figures 4 and 5. Ground water levels measured at the time of installation are also presented in Figures 4 and 5. The model PS9801 transducer is an electrical resistance type sensor that converts water pressure acting on a diaphragm to an analog voltage output. Each piezometer utilizes a vent tube that references atmospheric pressure, so pressure acting on the piezometer sensor represents the depth of water submergence. A central controller module (GCM) acquires readings from a transducer interface module (GST) connected to each piezometer and transmits the data to a server computer via a wireless Internet modem.

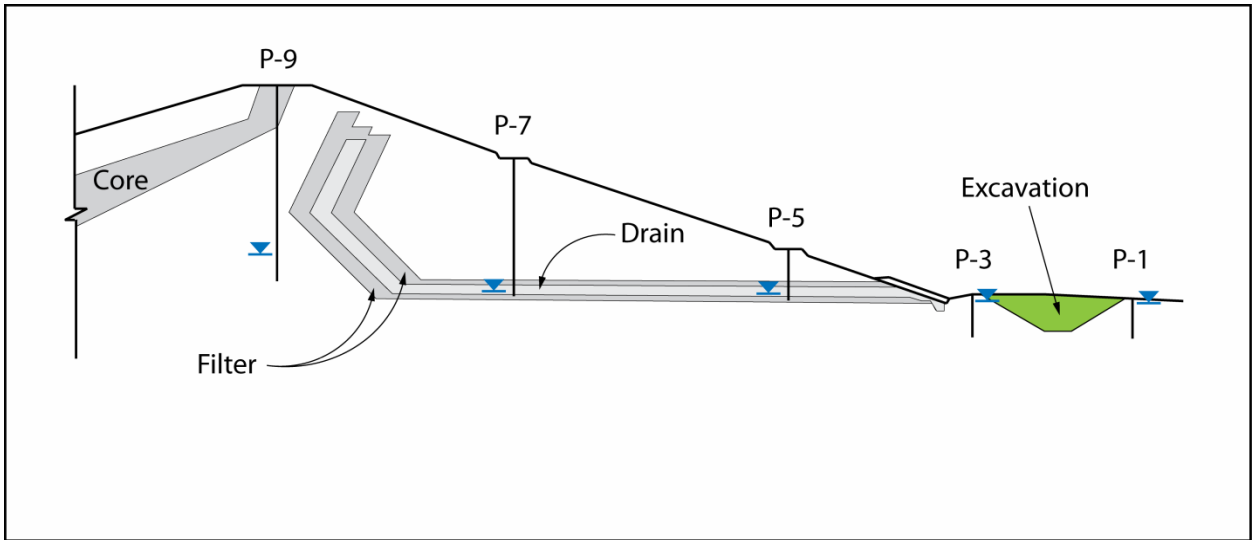

Figure 4. Piezometer Elevations for P-1, P-3, P-5, P-7 and P-9

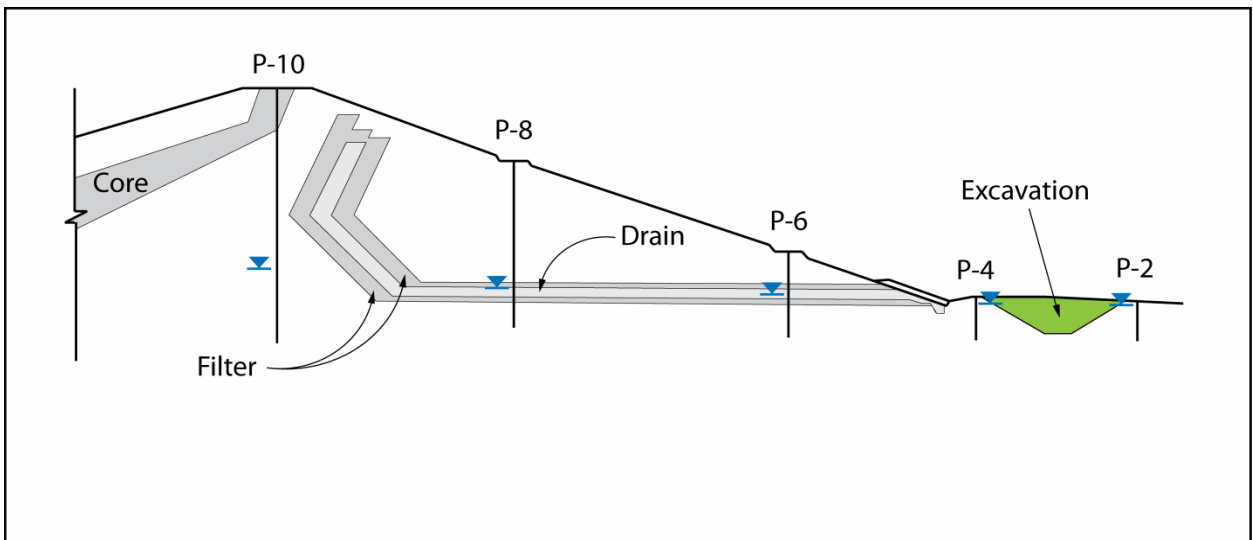

Figure 5. Piezometer Elevations for P-2, P-4, P-6, P-8, P-10

A total of four in-place inclinometers, designated IPI-1, IPI-2, IPI-3 and IPI-4, were installed within Perris Dam and at the toe of the dam as shown in Figure 6. The in-place inclinometers were manufactured by Geodaq, Inc. and consisted of numerous model INC500 modules connected end-to-end forming a long continuous network of tilt sensors. The total depth of IPI-1, IPI-2, IPI-3 and IPI-4 was 42.0, 59.0, 135.5 and 169.5 feet below ground surface, respectively, with sensors spaced 12-inches apart. Each sensor level includes a temperature sensor and a bi-axial tilt sensor consisting of Micro-Electro-Mechanical Systems (MEMS) accelerometers. Therefore, subsurface monitoring included a total of 384 temperature sensors and 768 tilt sensors. A unique feature of this monitoring project included enhanced detection of shear plane development resulting from a dense spatial distribution of sensors combined with frequent readings.

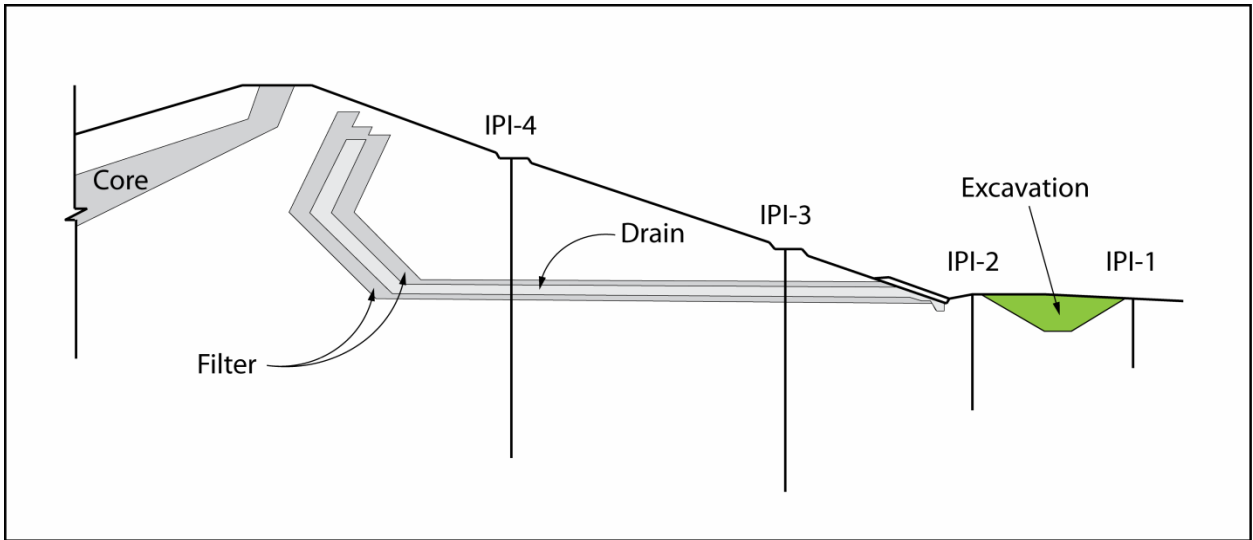

Figure 6. In-Place Incliner Elevations for IPI-1, IPI-2, IPI-3 and IPI-4

Each chain of INC500 modules was installed inside a standard 2.75-inch diameter inclinometer casing using a centralizer device with four wheels to track the inner grooves of the casing and provide accurate sensor alignment over the depth of the inclinometer casing. The INC500 module with centralizer is shown in Figure 7. A monitoring station at the ground surface includes one controller module (GCM) and one Internet modem (MDM) as shown in Figure 7. Figure 8 illustrates three field enclosures with all the necessary data collection hardware and battery. All piezometer and inclinometer readings were transmitted through the plastic field enclosures, so no external components were visible and all the monitoring instrumentation maintained a low profile.

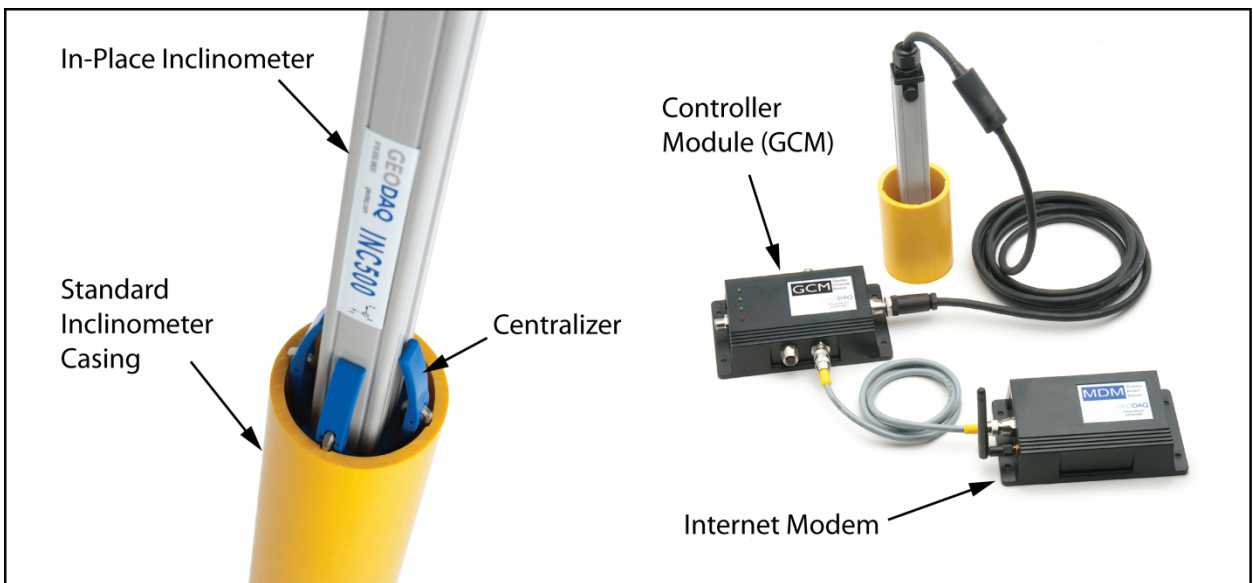

Figure 7. In-Place Incliner and Data Collection Hardware

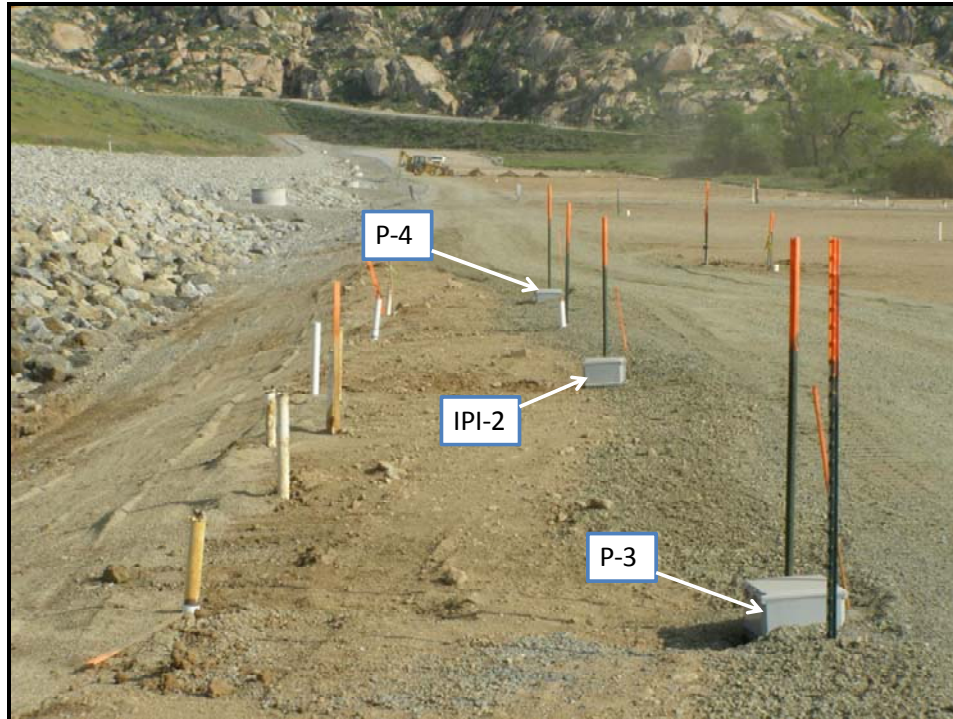

Figure 8. In-Place Inclinator and Piezometer Monitoring Stations

Data Collection and Transmission Procedure

The data collection and transmission sequence included the following steps: a) the GCM applied power to the in-place inclinometer or GST (piezometer stations), b) the GCM instructed the in-place inclinometer or GST to obtain a set of readings, c) readings are acquired over a digital network using a Controller Area Network (CAN) communication bus, d) the GCM disconnects power to the in-place inclinometer or GST module, e) the GCM applies power to the wireless Internet modem (MDM) and transmits data to a web server, f) the GCM receives a new command from the server and disconnects power to the MDM, and g) the GCM places itself into a sleep mode drawing low current from the battery until the next sample event.

Sample Frequency

A significant benefit of an automated monitoring system includes the ability to sample at frequent time intervals. Real-time monitoring is effective when the sample interval (time between samples) is frequent enough to capture the expected rate of change of each physical parameter being measured during the monitoring program, including unanticipated events. As a rule of thumb, a sample rate of at least 10 times the highest anticipated frequency should adequately characterize the event of interest. For example, if you expect that a limiting failure condition for a slope may occur over a period of one day, then a sample interval of about 2 hours or less should be implemented. Increasing the frequency of sample events does not reduce the quality of a monitoring program or the readings obtained and can provide the benefit of capturing unexpected events.

Figure 9 illustrates how an automated monitoring system can capture changes in ground water levels using sample intervals as often as every 3 minutes. It would be unreasonable to expect field personnel to record water level readings for 10 observation wells by hand during construction during the dewatering tests. Within a few weeks of implementation of the automated monitoring system, the cost savings and the technical advantages of increased temporal resolution of the real-time automated monitoring system became apparent.

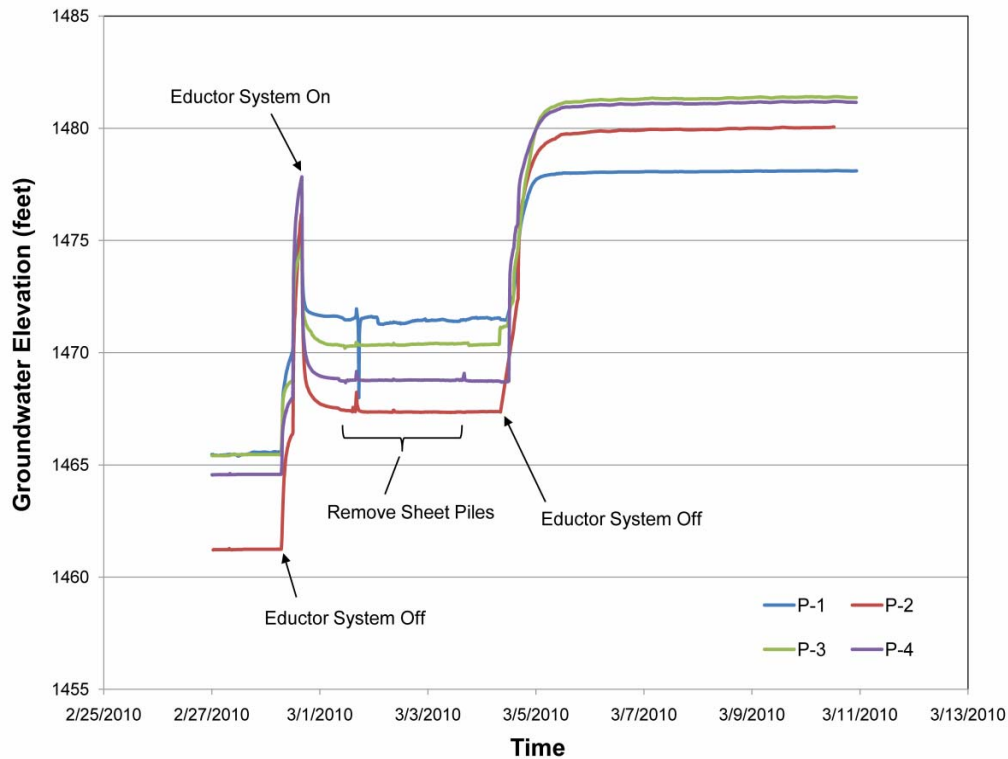

Figure 9. Typical Piezometer Readings

Figure 10 provides an illustration of how real-time monitoring with frequent sample events captured an unexpected drop in piezometer pressure readings due to the magnitude 7.2 earthquake in Baja California, Mexico. The lower plot shown in Figure 10 provides the complete set of readings from the automated monitoring system at piezometer P-8 with a sample interval ranging from every 2 to 6 hours. The upper plot in Figure 10 shows the same piezometer results using a monthly sample interval. It would be reasonable to conclude from the plot of monthly piezometer readings that the water level is gradually decreasing over time (note the magnitude of change in this example is very small). However, with the additional information provided in the lower plot from the automated monitoring system where frequent readings were acquired, a completely different conclusion emerges. The lower plot clearly indicates a drop in water level as a result of the magnitude 7.2 earthquake. Before the earthquake, the lower plot does not suggest a downward trend. After the earthquake, the plot shows a slight lowering trend, eventually leveling out. The upper plot with monthly readings correctly captures the

overall trend of a lowering water level and the eventual leveling off, but it does not record information that may actually explain why the water level changed in the first place. This simple example provides an illustration of how frequent sampling with a well designed automated monitoring system can increase one's ability to accurately interpret observed behavior.

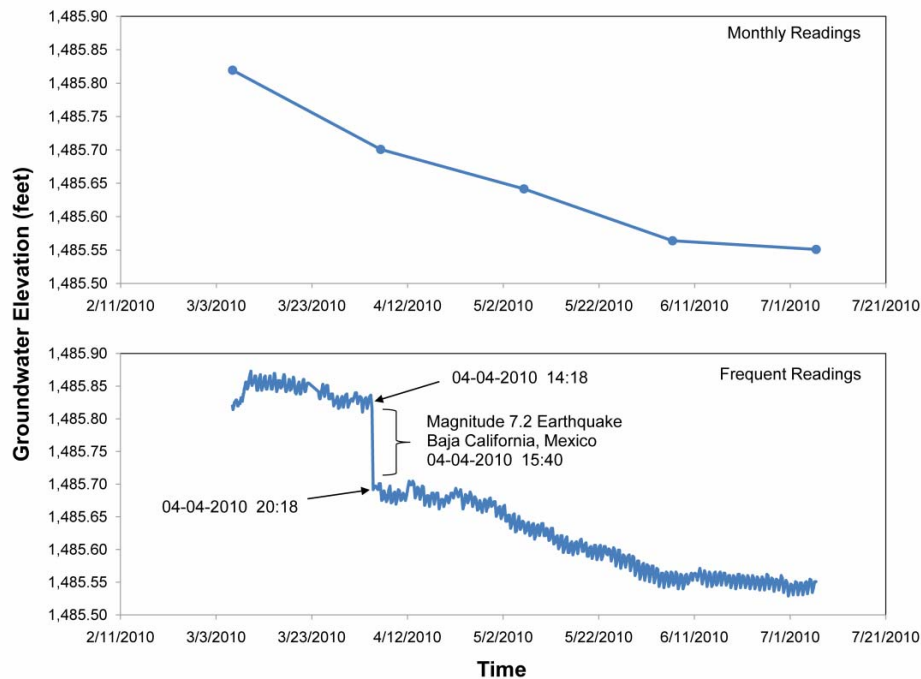

Figure 10. Comparison of Piezometer P-8 Readings at Different Sample Frequencies

Real-Time Evaluation and Threshold Criteria for Safety Monitoring

Three threshold criteria were established for both the in-place inclinometer and piezometer monitoring, each organized into three categories based on the relative significance of the reading. Level 1 was considered a variation from normal requiring notification and review of the data with possible increases to future sample frequency. Level 2 was considered significant, requiring notification and prompt review of the data with possible consultation with the contractor and design team depending on the results of the data review. Level 3 was considered very important requiring immediate notification, data review, and mandatory consultation with the contractor and design team including the Division of Safety of Dams. The criteria for the in-place inclinometer instrumentation were based on a maximum cumulative displacement occurring over a 24-hour period. The maximum cumulative displacement for inclinometer monitoring was set as 0.1, 0.2, and 0.3 inches for level 1, 2, and 3 thresholds, respectively. A slightly different threshold criteria was used for piezometer monitoring. A trigger was activated if the water level increased by 2 feet between the last two readings or 3 feet between the last three readings. An additional criteria was added during the period of excavation, and a trigger was activated if the elevation exceeded a specified level. For example, during excavation, if the water level at piezometer P-4 exceeded elevation 1466 feet, or if it

exceeded 2-feet over the last two readings, or if it exceeded 3-feet over the last three readings, then an automated notification was initiated.

In the event any data reduced from the instrumentation readings exceeded the established threshold levels, a computer generated phone message would automatically be sent with a description of what station exceeded the threshold criteria along with the measured value. A detailed plan was added to the project specifications that described what action would be required for a given notification. The required action varied with each threshold level. For example, a level 1 notification would be sent only to the Instrumentation Engineer and DWR Project Manager for review. In contrast, exceeding the level 3 threshold required the construction foreman to be on site within 30 minutes and key staff from the contractor and DWR to be on site within 60 minutes of notification. The automatic notification system was deactivated for some instrumentation at various times during construction based on the nature of the construction activity and the anticipated measurement changes. For example, the notification system was disabled for two of the in-place inclinometers when sheet piles were installed adjacent to the inclinometers. Similarly, the notification system was disabled for the piezometers during several periods during construction when it was anticipated that dewatering activity would initiate false notifications.

The majority of construction work requiring automated monitoring occurred during the period of time beginning in January and extending through the middle of March 2010. Figure 11 shows the maximum cumulative displacement results for in-place inclinometer IPI-4. The displacement threshold levels are also included on Figure 11 for comparison with the measured results. The results indicate that IPI-4 never exceeded the lowest displacement threshold criteria of 0.1 inches over a period of 24 hours. Cumulative displacements shown in Figure 11 and identified as “24-Hr Average” were calculated by averaging 12 hours of readings and comparing the resulting averaged profile with a set of readings (averaged over a 12 hour period) occurring 24 hours prior to the first set. In addition to the 12 hour averaging method, maximum cumulative displacements were also calculated using a single inclinometer reading and one reading 24-hours prior to the first. Figure 11 illustrates that using single reading events results in increased displacement calculations as expected without averaging, but both calculation methods produced displacements below the established level 1 criteria. None of the inclinometer instrumentation readings exceeded the level 1 threshold for this project.

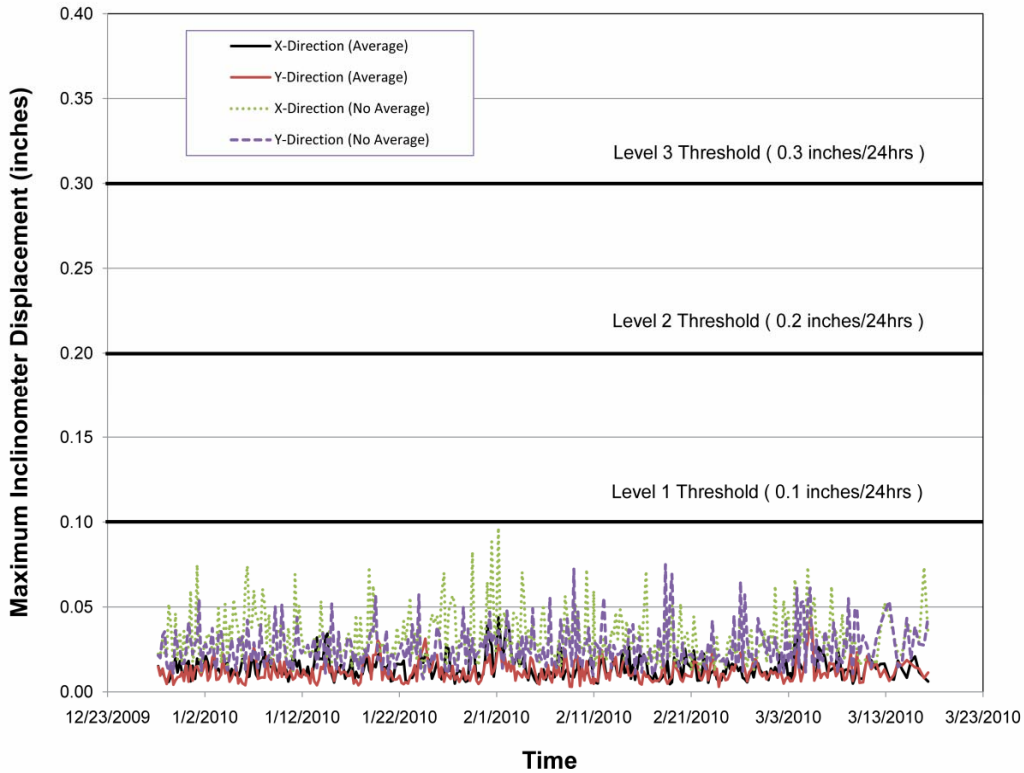

Figure 11. Maximum Displacements for 24-Hour Period, Inclinometer I-4

Web-Based Data Delivery

A useful automated monitoring system should deliver results in real-time to any location without unreasonable conditions. Once readings have been collected at a project site and transmitted to a secure data storage location, the next step is to deliver the results in some meaningful way to the user. One of the innovative approaches used for this project was a data delivery system providing the features of a desktop software application in a standard web browser without the need to purchase and install software. This feature allowed authorized project personnel to view graphs and tables of reduced data in real-time from any computer with a web browser and an Internet connection. In the event a Level 1 trigger notification occurred at night on a weekend, for example, project personnel could access current results, including data-reduced plots, from a home computer using a web browser. Figure 12 shows a screen shot of the web-based application used on this project. Displacement profiles and time-history plots illustrate how IPI-2 captured lateral movements during sheet pile installation and removal. Inclinometer IPI-2 was located adjacent to the sheet pile wall in the test excavation area.

This type of web-based software approach is commonly referred to as a Rich Internet Application (RIA). The RIA allows data delivery to move well beyond static delivery of data tables and simple color indicator icons or gif images of plots created on the server side. The scheme used for this project included the following steps: a) a body of raw data

is delivered to the RIA based on a request from the user, b) the user can select various options regarding how the raw data should be reduced, c) the RIA performs calculations locally and creates plots in response to user requests, d) the user can change various aspects about how the data is plotted and the RIA recalculates and re-plots the results, and e) the user can copy reduced data from a “data clipboard” area within the RIA and paste directly into a spreadsheet for further evaluation or report documentation. The application runs within a web browser and organizes the results of thousands of readings into a simple tab navigation system. Each tab panel typically has several additional navigation tabs containing detailed plots or data tables of reduced data. The user has the option to select various analysis methods, plot characteristics, time windows, and time-history plots.

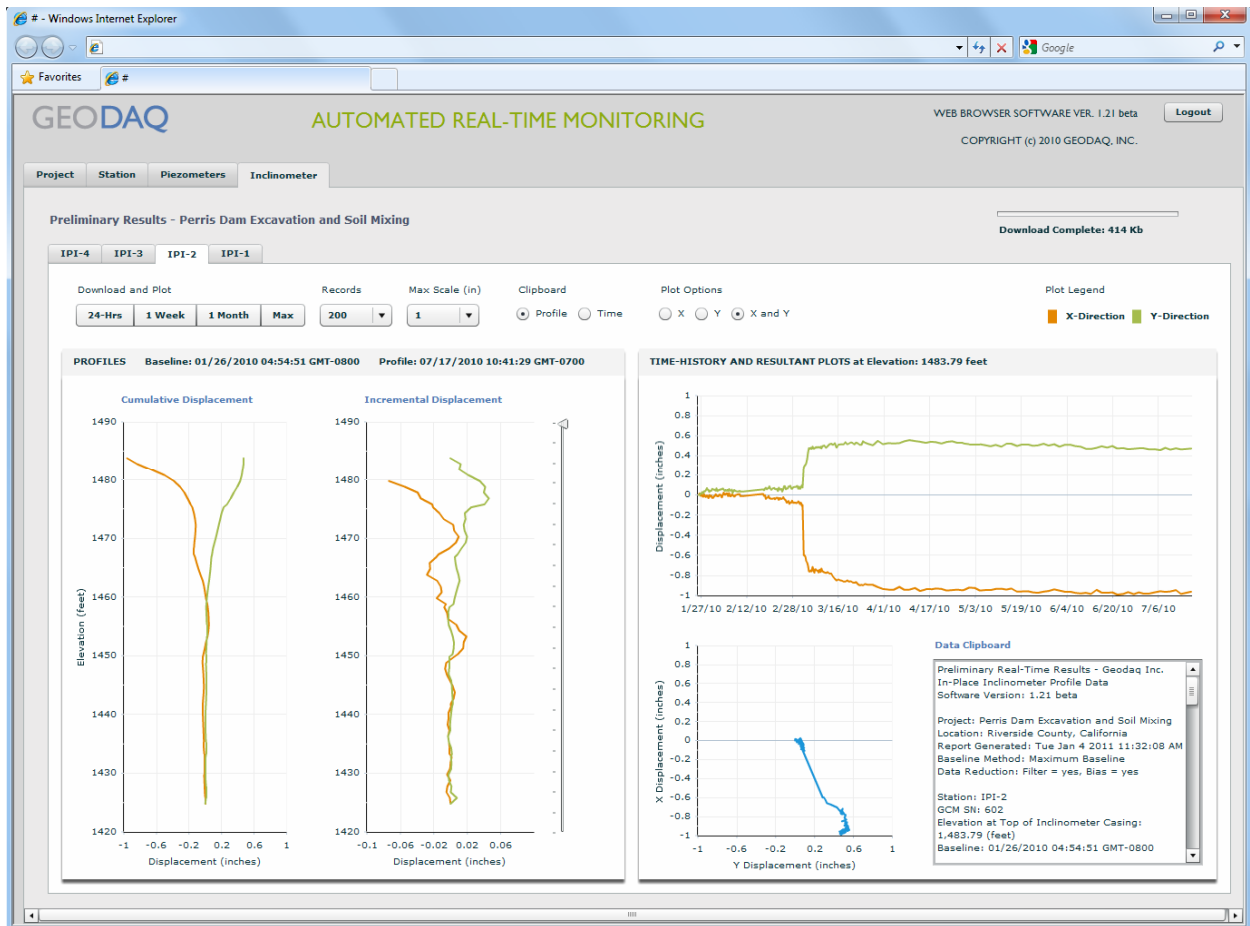

Figure 12. Web-Based Rich Internet Application (RIA) Displaying Results During Sheet Pile Installation and Removal

CONCLUSIONS

Continuing advances in technology provide an ever-increasing level of measurement ability, density of sensor deployment, wireless data transfer, and graphical data presentation. Web-based monitoring provides a reliable way to simplify data collection and presentation. Several key elements were involved in the automated monitoring

system used at Perris Dam: 1) a significant number of measurement points captured the physical behavior being monitored and provided an enhanced measurement criteria for identification of potential shear plane development based on closely spaced inclinometer sensors, 2) frequent sampling adequately characterized the performance of the dam during construction and provided continuous observation to increase safety, 3) real-time evaluation of instrumentation measurements provided a robust automatic notification system, and 4) browser based software with interactive charting and analysis tools moved real-time data delivery beyond static data tables and plots delivered as gif images in standard HTML pages, and 5) significant cost savings associated with automation of data collection, data reduction, plotting, and evaluation of data to determine if immediate corrective action is needed.

In this project there was no automated alarm triggers and thus no automated notifications or response. The continuous monitoring program was considered a success, however, in that even developing the multi-tiered response strategy contributed to a more thorough communication of risks and concerns to all stakeholders.

The test construction phase concluded in March 2010. The data collected during the construction activities is being analyzed by the design teams in evaluating the proposed techniques toward determining the final remediation strategies to be used at Perris Dam.

REFERENCE

California Department of Water Resources (2005). "Perris Dam Foundation Study."

